

## Threaded End/Socket Weld End Fig. 10 - Series 1000/ Fig. 71 - Series 7100

Designed and Manufactured  
in accordance with ASME B16.34

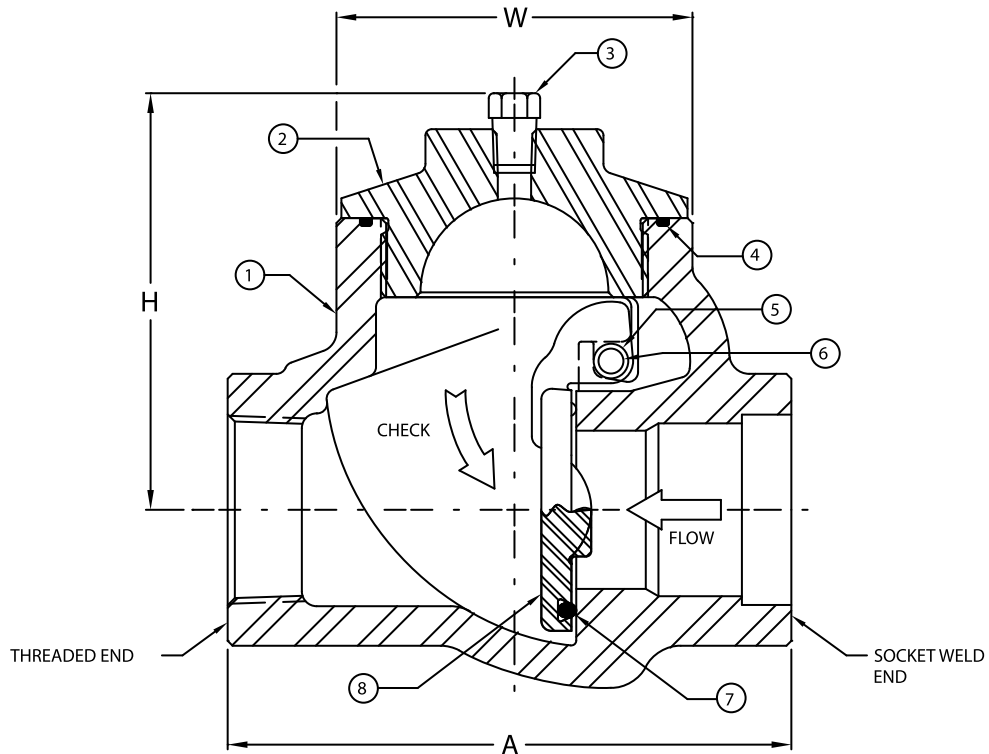

### Parts List

No.	Part	Material
1	Body	ASTM A216-WCB / WCC <sup>(1)(2)</sup>
2	Cap	ASTM A216-WCB / WCC ASTM A105 <sup>(1)(2)</sup>
3	Pipe Plug <sup>(3)</sup>	ASTM A105 <sup>(1)</sup>
4	Cap Seal	Viton® or like material <sup>(4)</sup>
5	Clapper Bushing	Stainless Steel
6	Clapper Pin	Stainless Steel
7	Clapper	ASTM A351-CF8M
8	Clapper Seal	Viton® or like material <sup>(4)</sup>

#### Notes:

- (1) ASTM A352-LCC / ASTM A350-LF2 for low temperature service
- (2) ASTM A351-CF8M or ASTM A351-CF3M for corrosive service
- (3) For valves NPS 2" & larger
- (4) HSN for low temperature service

Viton® is a registered trademark of DuPont Dow Elastomers



## Crown Swing Check Valves

### Threaded End/Socket Weld End Fig. 10 - Series 1000/ Fig. 71 - Series 7100

Designed and Manufactured  
in accordance with ASME B16.34

Valve Size Inch (mm)	ASME Class	“A” Inch (mm)	“H” Inch (mm)	“W” Inch (mm)	Weight lbs (kg)
1/2 (13)	150	4.13 (104.9)	3.00 (76.2)	2.75 (69.9)	4 (2)
	300	4.13 (104.9)	3.00 (76.2)	2.75 (69.9)	4 (2)
	600	4.13 (104.9)	3.00 (76.2)	2.75 (69.9)	4 (2)
	800	4.13 (104.9)	3.00 (76.2)	2.75 (69.9)	4 (2)
	864	4.13 (104.9)	3.00 (76.2)	2.75 (69.9)	4 (2)
	900	4.13 (104.9)	3.00 (76.2)	2.75 (69.9)	4 (2)
	1200	4.25 (108.0)	3.34 (84.8)	2.88 (73.2)	6 (3)
3/4 (19)	150	4.13 (104.9)	3.00 (76.2)	2.75 (69.9)	4 (2)
	300	4.13 (104.9)	3.00 (76.2)	2.75 (69.9)	4 (2)
	600	4.13 (104.9)	3.00 (76.2)	2.75 (69.9)	4 (2)
	800	4.13 (104.9)	3.00 (76.2)	2.75 (69.9)	4 (2)
	864	4.13 (104.9)	3.00 (76.2)	2.75 (69.9)	4 (2)
	900	4.13 (104.9)	3.00 (76.2)	2.75 (69.9)	4 (2)
	1200	4.25 (108.0)	3.34 (84.8)	2.88 (73.2)	6 (3)
1 (25)	150	4.25 (108.0)	3.34 (84.8)	2.88 (73.2)	6 (3)
	300	4.25 (108.0)	3.34 (84.8)	2.88 (73.2)	6 (3)
	600	4.25 (108.0)	3.34 (84.8)	2.88 (73.2)	6 (3)
	800	4.25 (108.0)	3.34 (84.8)	2.88 (73.2)	6 (3)
	864	4.25 (108.0)	3.34 (84.8)	2.88 (73.2)	6 (3)
	900	4.25 (108.0)	3.34 (84.8)	2.88 (73.2)	6 (3)
	1200	4.25 (108.0)	3.34 (84.8)	2.88 (73.2)	6 (3)
1 1/2 (38)	150	5.88 (149.4)	4.13 (104.9)	3.75 (95.3)	16 (8)
	300	5.88 (149.4)	4.13 (104.9)	3.75 (95.3)	16 (8)
	600	5.88 (149.4)	4.13 (104.9)	3.75 (95.3)	16 (8)
	800	5.88 (149.4)	4.13 (104.9)	3.75 (95.3)	16 (8)
	864	5.88 (149.4)	4.13 (104.9)	3.75 (95.3)	16 (8)
	900	5.88 (149.4)	4.13 (104.9)	3.75 (95.3)	16 (8)
	1200	5.88 (149.4)	4.13 (104.9)	3.75 (95.3)	16 (8)
	1500	5.88 (149.4)	4.13 (104.9)	3.75 (95.3)	16 (8)
	1800	5.88 (149.4)	4.13 (104.9)	3.75 (95.3)	16 (8)
2 (50)	150	7.13 (181.1)	5.34 (135.6)	4.50 (114.3)	20 (10)
	300	7.13 (181.1)	5.34 (135.6)	4.50 (114.3)	20 (10)
	600	7.13 (181.1)	5.34 (135.6)	4.50 (114.3)	20 (10)
	800	7.13 (181.1)	5.34 (135.6)	4.50 (114.3)	20 (10)
	864	7.13 (181.1)	5.34 (135.6)	4.50 (114.3)	20 (10)
	900	7.13 (181.1)	5.34 (135.6)	4.50 (114.3)	20 (10)
	1200	7.50 (190.5)	5.81 (147.6)	5.0 (127.0)	34 (17)
	1500	7.50 (190.5)	5.81 (147.6)	5.0 (127.0)	34 (17)
	1800	7.50 (190.5)	5.81 (147.6)	5.0 (127.0)	34 (17)

*Weight and dimensional information for reference only and subject to change without notice.  
Weights and dimensions can be confirmed at time of order.*

FIG10-FIG71-VERSION-01-B16.34