

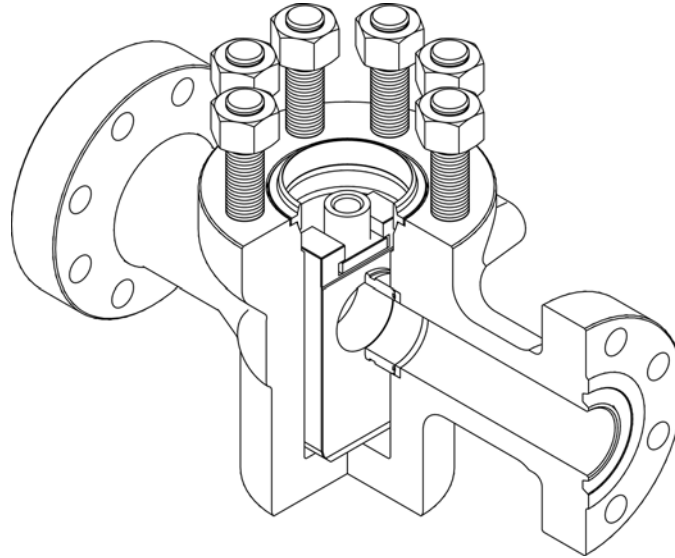

Reverse Acting Gate Valves



Stream-Flo offers a variety of Crown gate valve models prepared for pneumatic or hydraulic actuators. Valves are bidirectional and most commonly reverse acting for fail safe closed applications. Valves are available from 2000 to 15000 psi working pressures and can be supplied in 1¹³/₁₆" to 7¹/₁₆" sizes in flanged, threaded, hub end or composite block valve configurations.

Reverse Acting Gate Valve Models

Nominal Size inches (mm)	2000 psi (13.8 MPa)	3000 psi (20.7 MPa)	5000 psi (34.5 MPa)	10000 psi (69.0 MPa)	15000 psi (138.0 MPa)
1 ¹³ / ₁₆ (46)	S / SL	S / SL	S / SL	SL	SL
2 ¹ / ₁₆ (52)	S / SL	S / SL	S / SL	SL	SL
2 ⁹ / ₁₆ (65)	S / SL	S / SL	S / SL	SL	SL
3 ¹ / ₁₆ (78)	-	-	-	SL	SL
3 ¹ / ₈ (79)	S / SL	S / SL	S / SL	-	-
4 ¹ / ₁₆ (103)	S / SL	S / SL	S / SL	SL	-
5 ¹ / ₈ (130)	B / SL	B / SL	B / SL	SL	-
7 ¹ / ₁₆ (179)	B / SL	B / SL	B / SL	-	-

The 7¹/₁₆" Model 'B' is available with 6¹/₈" (155 mm) or 6³/₈" (162 mm) bore.
SL shown above is available in Model SL-A or SL-2 (Patent Pending).
Additional sizes available upon request.

General Design and Construction Features:

- Bidirectional design - the valve can be used in either direction.
- Stem backseating capability.
- Gate or seats can be replaced on line.
- Body cavity is filled with grease to lubricate components and prevent accumulation of foreign materials or hydrates.
- Full bore / thru-conduit flow with no discontinuities at sealing surfaces minimizes pressure drop and turbulence.
- Adapts easily to any make or style of actuator.

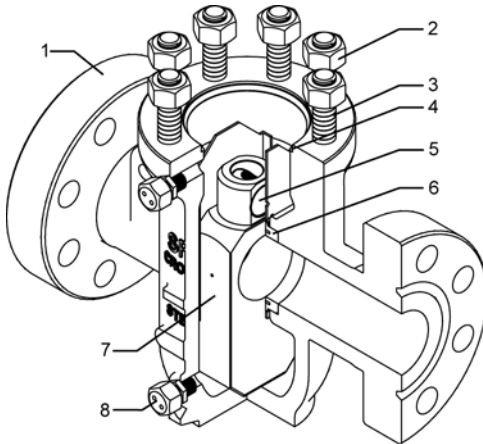

Model 'S'

- cast body
- solid slab gate
- floating seats
- metal-to-metal gate to seat and seat to body seal
- non-elastomeric seat seal ring enhances low pressure sealing between gate and seats
- two body grease fittings

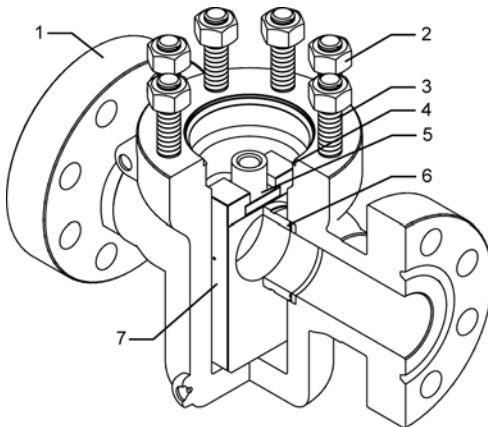

Model 'SL' *

- forged body
- solid slab gate
- floating seats
- metal-to-metal gate to seat and seat to body seal
- Model SL-2 patent pending feature, an annular protrusion on the seat carrier maintains constant contact with the non-elastomeric seat seal ensuring low pressure sealing
- Model SL-2 is SSV certified to PR-2, Class II
- no body penetrations, grease fitting provided on bonnet above stem backseat

* Available in Model 'SL-A' or 'SL-2'

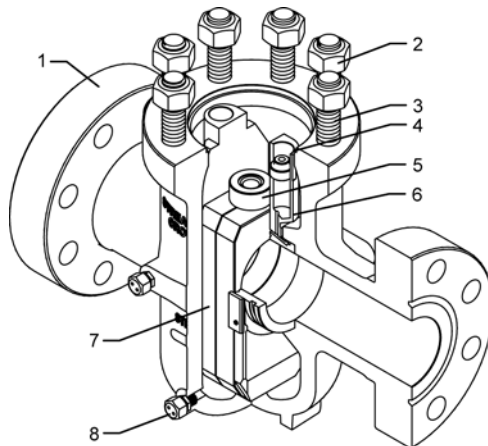

Model 'B'

- cast body
- two spring loaded split gates
- interference fit fully skirted seats
- sealing is enhanced by an auto-seal system whereby internal pressure transmits sealing compound from reservoirs in the seats to grooves on the seat faces to prevent leaks
- one body grease fitting, second grease fitting present on bonnet above stem backseat
- two body sealant fittings to replenish sealant in seat reservoirs

Parts List

1 body	5 lift nut
2 nut	6 seat (assembly)
3 stud	7 gate (assembly)
4 bonnet gasket	8 body grease fitting

Standard and special trims available. Contact Stream-Flo for dimensional data or information to interface with actuator.