

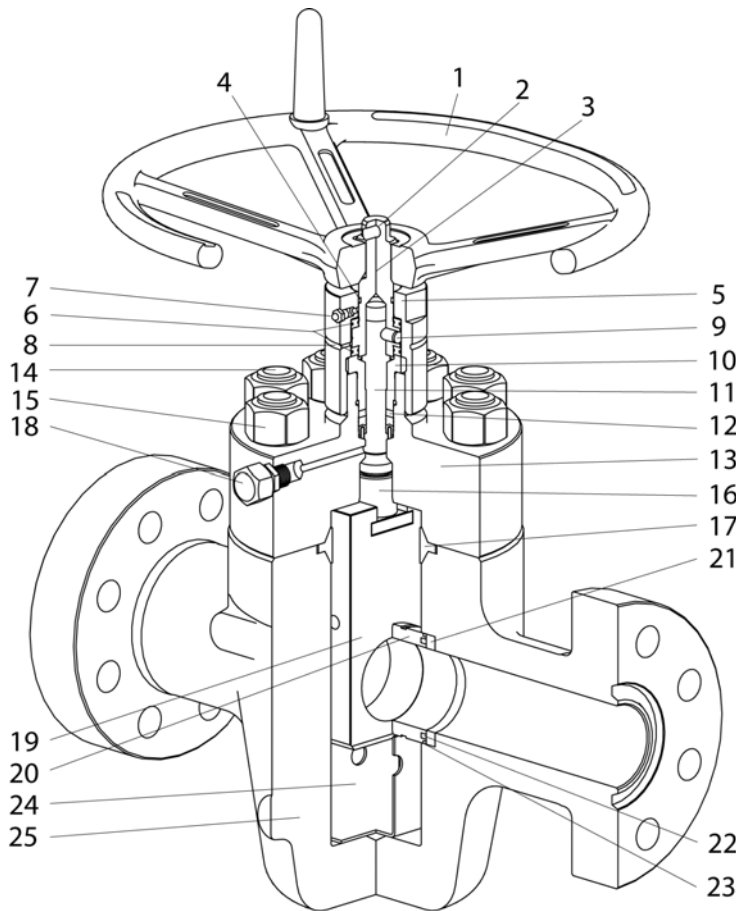

Crown Model SL-2 Gate Valve



Parts List

1	handwheel
2	quick release pin
3	stem adapter
4	o-ring
5	bearing housing
6	thrust bearing
7	grease zert
8	o-ring
9	shear pin
10	packing retainer
11	stem
12	stem packing
13	bonnet
14	stud
15	nut
16	lift nut
17	bonnet seal
18	grease fitting
19	gate
20	seat
21	seat carrier
22	seat seal, inner
23	seat seal, outer
24	gate guide
25	body

note: bonnet seal #17 will differ for 2000 to 5000 psi valves

The Crown Model SL-2 gate valve is a bidirectional valve that utilizes a slab gate and floating seats to provide sealing in a wide variety of applications. This valve is available from 2000 to 15,000 psi working pressures and can be supplied in sizes 1¹³/₁₆" to 7¹/₁₆". The model SL-2 is O.C.S.G. certified, SSV to PR-2 Class II.

Design and Construction Features:

- Forged valve body and bonnet.
- Floating seats and slab gate provides metal-to-metal, gate to seat and seat to body seals.
- Corrosion resistant seat carrier protects body pockets.
- Patent-pending feature: annular protrusion on the seat carrier maintains constant contact with non-elastomeric seat seal ensuring low pressure sealing.
- Non-rising stem has backseating capability allowing stem packing and bearings to be replaced under pressure.
- Stem packing is spring loaded non-elastomeric material.
- Shear pin on stem provides over torque protection.
- Pressure energized metal-to-metal bonnet seal.
- No body penetrations. For body lubrication, one grease fitting is provided on the bonnet above the stem backseat.
- Body cavity is filled with grease to lubricate components and prevent accumulation of foreign materials or hydrates.
- Full bore/thru-conduit flow with no discontinuities at sealing surfaces minimizes pressure drop and turbulence.
- Handwheel attached with quick-release pin for easy removal.



Crown Gate Valves

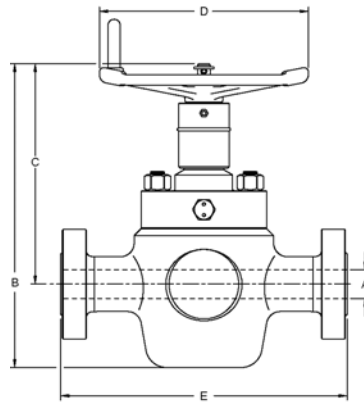

Dimensional Data

psi (MPa)	Size (mm)	A	B	C	D	E	N	T	Wt
2000 (13.8)	2 1/16 (52)	2.06	19.75	14.63	11.0	11.62	12.0	15	170
	2 9/16 (65)	2.56	20.81	15.69	12.5	13.12	14.0	15	220
	3 1/8 (79)	3.19	24.00	16.25	12.5	14.12	18.5	20	280
	4 1/16 (103)	4.12	27.50	18.00	16.0	17.12	23.5	25	400
3000 (20.7)	2 1/16 (52)	2.06	20.38	15.19	12.5	14.62	12.0	20	190
	2 9/16 (65)	2.56	21.44	16.25	12.5	16.62	14.0	20	235
	3 1/8 (79)	3.19	24.19	16.94	16.0	17.12	18.5	25	320
	4 1/16 (103)	4.12	28.12	18.81	20.0	20.12	23.5	30	515
	5 1/8 (130)	5.12	30.12	20.69	20.0	24.12	29.0	50	850
5000 (34.5)	7 1/16 (179)	6.38	35.38	21.75	20.0	24.12	36.0	85	1150
	2 1/16 (52)	2.06	20.38	15.19	12.5	14.62	12.0	25	190
	2 9/16 (65)	2.56	21.44	16.25	12.5	16.62	14.0	30	235
	3 1/8 (79)	3.19	24.69	16.94	16.0	18.62	18.5	40	335
10,000 (69.0)	4 1/16 (103)	4.12	28.56	18.81	20.0	21.62	23.5	50	525
	5 1/8 (130)	5.12	33.56	20.69	26.0	28.62	29.0	80	850
	7 1/16 (179)	6.38	35.88	22.25	26.0	29.00	36.0	150	1500
	2 1/16 (52)	2.06	20.69	15.19	16.0	20.50	12.0	50	280
15,000 (138.0)	2 9/16 (65)	2.56	21.69	16.38	20.0	22.25	14.0	55	420
	3 1/16 (78)	3.06	24.81	16.94	20.0	24.38	18.5	70	495
	4 1/16 (103)	4.06	29.31	18.81	26.0	26.38	23.5	115	875
	5 1/8 (130)	5.12	31.31	20.69	26.0	29.00	29.0	270	1240
15,000 (138.0)	2 1/16 (52)	2.06	22.75	15.88	16.0	19.00	14.0	70	410
	2 9/16 (65)	2.56	24.00	16.88	20.0	21.00	15.5	115	505
	3 1/16 (78)	3.06	27.50	18.25	20.0	23.56	19.0	140	790

Dimensions in inches

N = number of turns required to open

T = opening torque at full differential pressure in ft-lbs (may vary depending on service conditions)

Wt = lbs

Trim Chart

Service	Trim	Matl Class	Body & Bonnet	Bonnet Seal	Gate (2)	Seat (2)	Stem
general oilfield oil and gas	T-21	AA	alloy steel	CS	alloy steel	alloy steel	alloy steel
general oilfield low temp -50 °F	T-36	AA	alloy steel	CS	alloy steel	alloy steel	alloy steel
general with slight CO ₂ corrosion	T-22	BB	alloy steel	SS	13 Cr SS	13 Cr SS	17-4 PH
corrosive with high CO ₂	T-23	CC	13 Cr SS	SS	13 Cr SS	13 Cr SS	17-4 PH
SOG	T-24	DD-NL	alloy steel	SS	alloy steel	alloy steel	alloy steel
SOG	T-24N	DD-NL	alloy steel	SS	alloy steel	alloy steel	CRA
SOG	T-24Z	DD-0.5/ZZ	alloy steel	SS	alloy steel	alloy steel	17-4 PH
SOG	UD	DD-NL	alloy steel	CS	alloy steel	alloy steel	alloy steel
SOG low temp -50 °F	T-37	DD-NL	alloy steel	SS	alloy steel	alloy steel	alloy steel
slight CO ₂ corrosion and SOG	T-25	EE-0.5/ZZ	alloy steel	SS	13 Cr SS	13 Cr SS	17-4 PH
slight CO ₂ corrosion and SOG	T-25N	EE-NL	alloy steel	SS	13 Cr SS	13 Cr SS	CRA
corrosive with high CO ₂ and SOG	T-26	FF-0.5/ZZ	13 Cr SS	SS	13 Cr SS	13 Cr SS	17-4 PH
corrosive with high CO ₂ and SOG	T-26N	FF-NL	13 Cr SS	SS	13 Cr SS	13 Cr SS	CRA
extremely corrosive	T-78	HH-NL	CRA (1)	CRA	CRA	CRA	CRA

SOG sour oil and gas H₂S NACE MR0175

(1) or Alloy Steel Clad 625

(2) hardfaced or surface hardened

Materials subject to change without notice. Additional trims available.