

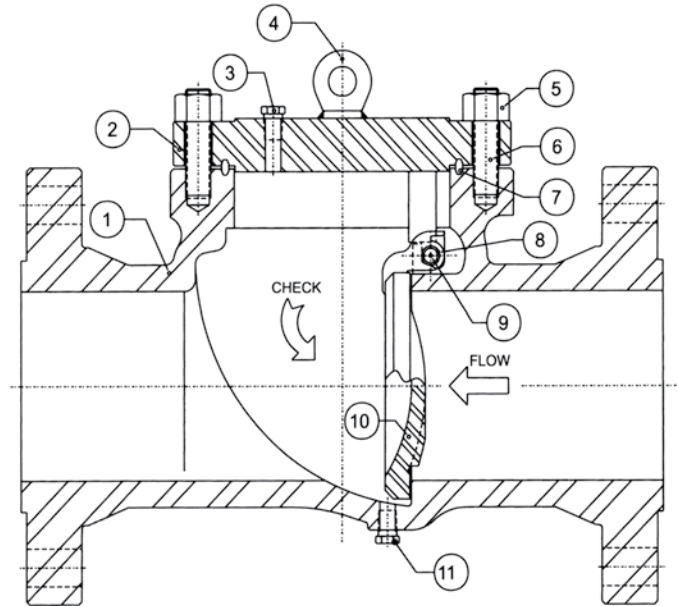

Crown Swing Check Valves

For High Temperature Services



Similar in design and construction to standard swing check valves, these valves are suitable for high temperature service conditions. End flange connections can either be raised-face or ring-type joint. The metal-to-metal clapper seal together with the metal ring-joint or spiral wound cover gasket (not shown) will assure long and dependable services. Consult factory for more details.

Parts List

No.	Part	Material
1	Body	carbon/low alloy steel
2	Cover	carbon/low alloy steel
3	Vent plug	carbon steel
4	Lifting eye/lug ⁽¹⁾	carbon steel
5	Cover nut	low alloy steel
6	Cover stud	low alloy steel
7	Cover ring gasket	mild or stainless steel
8	Bushing	stainless steel
9	Clapper pin	stainless steel
10	Clapper	carbon/low alloy steel
11	Drain plug ⁽²⁾	carbon steel

Notes:

⁽¹⁾ Lifting eye/lug is for valves 6" and larger.

⁽²⁾ Optional drain plug is for valves 6" and larger.



Crown Swing Check Valves

For High Temperature Services

Optional Removable Seats

Certain critical situations may require the use of removable seats due to extremely corrosive or erosive service. Normally this option may be recommended where monitoring of the seat condition is permissible or maintenance intervals are consistent. Where such conditions exist, Stream-Flo can provide the check valves with removable seats. Should seating maintenance be necessary, the entire seat ring assembly can be removed from the valve body and the worn parts replaced.

Features

As with all Crown swing check valves, modifications are required for vertical flow-up service. In addition, the all-steel construction maintains the valve integrity. The 12" and smaller seat are threaded into the body, whereas the 14" and larger are secured by recessed stainless steel set screws.

Options

The following optional features can be provided:

- alternate materials of construction
- o-ring seal contained in the removable seat ring
- compliance with NACE MR0175 for sour gas service is standard
- metal-to-metal seal

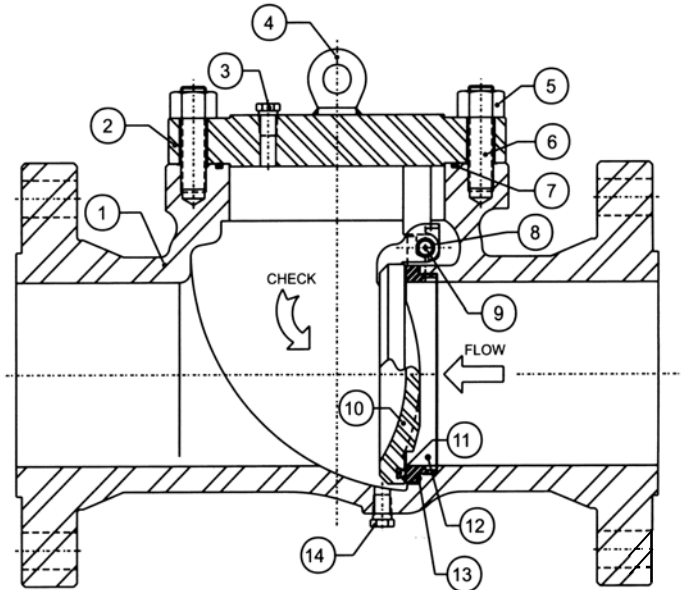

Parts List

No.	Part	Material
1	Body	carbon/low alloy steel
2	Cover	carbon/low alloy steel
3	Vent plug	carbon steel
4	Lifting eye/lug ⁽¹⁾	carbon steel
5	Cover nut	low alloy steel
6	Cover stud	low alloy steel
7	Cover seal (inner)	BUNA Nitrile/Viton [®]
8	Bushing	stainless steel
9	Clapper pin	stainless steel
10	Clapper	carbon/low alloy steel
11	Clapper seal	BUNA Nitrile/Viton [®]
12	Removable seat	carbon/low alloy steel
13	Removable seat seal	BUNA Nitrile/Viton [®]
14	Drain plug ⁽²⁾	carbon steel

Notes:

⁽¹⁾ Lifting eye/lug is for valves 6" and larger. Larger valves have more than one.

⁽²⁾ Optional drain plug is for valves 6" and larger.

Viton is a registered trademark of DuPont Dow Elastomers.