

Threaded End / Socket Weld End
Fig. 10 - Series 1000/ Fig. 71 - Series 7100
 Designed and Manufactured in accordance with ASME B16.11

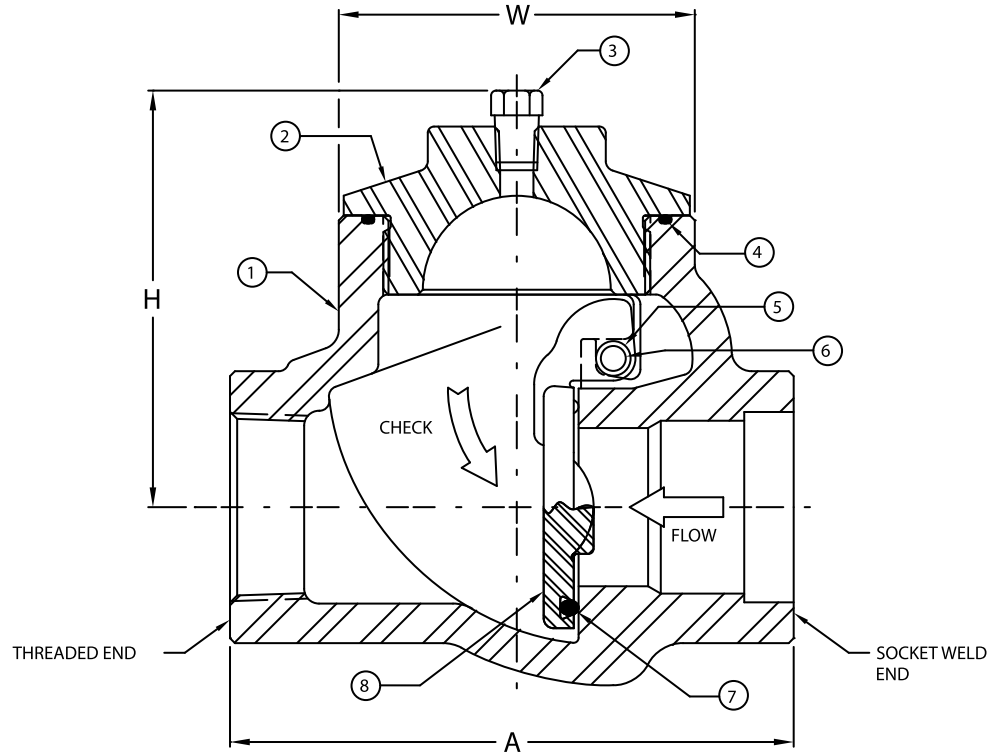

Parts List

No.	Part	Material
1	Body	ASTM A216-WCB / WCC ⁽¹⁾⁽²⁾
2	Cap	ASTM A216-WCB / WCC
3	Pipe Plug ⁽³⁾	ASTM A105 ⁽¹⁾⁽²⁾
4	Cap Seal	Viton® or equivalent material ⁽⁴⁾
5	Clapper Bushing	Stainless Steel
6	Clapper Pin	Stainless Steel
7	Clapper	ASTM A351-CF8M
8	Clapper Seal	Viton® or equivalent material ⁽⁴⁾

Notes:

- (1) ASTM A352-LCC / ASTM A350-LF2 for low temperature service
- (2) ASTM A351-CF8M or ASTM A351-CF3M for corrosive service
- (3) For valves NPS 2" & larger
- (4) HSN for low temperature service

Viton® is a registered trademark of DuPont Dow Elastomers



Crown Swing Check Valves



Threaded End / Socket Weld End
Fig. 10 - Series 1000/ Fig. 71 - Series 7100
 Designed and Manufactured in accordance with ASME B16.11

Valve Size Inch (mm)	Pressure Rating Psig	"A" Inch (mm)	"H" Inch (mm)	"W" Inch (mm)	Weight lbs (kg)
1/2 (13)	300	4.13 (104.9)	3.00 (76.2)	2.75 (69.9)	4 (2)
	500	4.13 (104.9)	3.00 (76.2)	2.75 (69.9)	4 (2)
	720	4.13 (104.9)	3.00 (76.2)	2.75 (69.9)	4 (2)
	1000	4.13 (104.9)	3.00 (76.2)	2.75 (69.9)	4 (2)
	1500	4.13 (104.9)	3.00 (76.2)	2.75 (69.9)	4 (2)
	1925	4.13 (104.9)	3.00 (76.2)	2.75 (69.9)	4 (2)
	2000	4.13 (104.9)	3.00 (76.2)	2.75 (69.9)	4 (2)
	2160	4.13 (104.9)	3.00 (76.2)	2.75 (69.9)	4 (2)
	2250	4.13 (104.9)	3.00 (76.2)	2.75 (69.9)	4 (2)
	3000	4.25 (108.0)	3.34 (84.8)	2.88 (73.2)	6 (3)
3/4 (19)	300	4.13 (104.9)	3.00 (76.2)	2.75 (69.9)	4 (2)
	500	4.13 (104.9)	3.00 (76.2)	2.75 (69.9)	4 (2)
	720	4.13 (104.9)	3.00 (76.2)	2.75 (69.9)	4 (2)
	1000	4.13 (104.9)	3.00 (76.2)	2.75 (69.9)	4 (2)
	1500	4.13 (104.9)	3.00 (76.2)	2.75 (69.9)	4 (2)
	1925	4.13 (104.9)	3.00 (76.2)	2.75 (69.9)	4 (2)
	2000	4.13 (104.9)	3.00 (76.2)	2.75 (69.9)	4 (2)
	2160	4.13 (104.9)	3.00 (76.2)	2.75 (69.9)	4 (2)
	2250	4.13 (104.9)	3.00 (76.2)	2.75 (69.9)	4 (2)
	3000	4.25 (108.0)	3.34 (84.8)	2.88 (73.2)	6 (3)
1 (25)	300	4.25 (108.0)	3.34 (84.8)	2.88 (73.2)	6 (3)
	500	4.25 (108.0)	3.34 (84.8)	2.88 (73.2)	6 (3)
	720	4.25 (108.0)	3.34 (84.8)	2.88 (73.2)	6 (3)
	1000	4.25 (108.0)	3.34 (84.8)	2.88 (73.2)	6 (3)
	1500	4.25 (108.0)	3.34 (84.8)	2.88 (73.2)	6 (3)
	1925	4.25 (108.0)	3.34 (84.8)	2.88 (73.2)	6 (3)
	2000	4.25 (108.0)	3.34 (84.8)	2.88 (73.2)	6 (3)
	2160	4.25 (108.0)	3.34 (84.8)	2.88 (73.2)	6 (3)
	2250	4.25 (108.0)	3.34 (84.8)	2.88 (73.2)	6 (3)
	3000	4.25 (108.0)	3.34 (84.8)	2.88 (73.2)	6 (3)
1 1/2 (38)	300	5.88 (149.4)	4.13 (104.9)	3.75 (95.3)	16 (8)
	500	5.88 (149.4)	4.13 (104.9)	3.75 (95.3)	16 (8)
	720	5.88 (149.4)	4.13 (104.9)	3.75 (95.3)	16 (8)
	1000	5.88 (149.4)	4.13 (104.9)	3.75 (95.3)	16 (8)
	1500	5.88 (149.4)	4.13 (104.9)	3.75 (95.3)	16 (8)
	1925	5.88 (149.4)	4.13 (104.9)	3.75 (95.3)	16 (8)
	2000	5.88 (149.4)	4.13 (104.9)	3.75 (95.3)	16 (8)
	2160	5.88 (149.4)	4.13 (104.9)	3.75 (95.3)	16 (8)
	2250	5.88 (149.4)	4.13 (104.9)	3.75 (95.3)	16 (8)
	3000	5.88 (149.4)	4.13 (104.9)	3.75 (95.3)	16 (8)
2 (50)	300	7.13 (181.1)	5.34 (135.6)	4.50 (114.3)	20 (10)
	500	7.13 (181.1)	5.34 (135.6)	4.50 (114.3)	20 (10)
	720	7.13 (181.1)	5.34 (135.6)	4.50 (114.3)	20 (10)
	1000	7.13 (181.1)	5.34 (135.6)	4.50 (114.3)	20 (10)
	1500	7.13 (181.1)	5.34 (135.6)	4.50 (114.3)	20 (10)
	1925	7.13 (181.1)	5.34 (135.6)	4.50 (114.3)	20 (10)
	2000	7.13 (181.1)	5.34 (135.6)	4.50 (114.3)	20 (10)
	2160	7.13 (181.1)	5.34 (135.6)	4.50 (114.3)	20 (10)
	2250	7.13 (181.1)	5.34 (135.6)	4.50 (114.3)	20 (10)
	3000	7.50 (190.5)	5.81 (147.6)	5.00 (127.0)	34 (17)
	5000	7.50 (190.5)	5.81 (147.6)	5.00 (127.0)	34 (17)
	5000	7.50 (190.5)	5.81 (147.6)	5.00 (127.0)	34 (17)
3 (76)	300	8.25 (209.6)	6.58 (166.9)	5.50 (139.7)	40 (18)
	500	8.25 (209.6)	6.58 (166.9)	5.50 (139.7)	40 (18)
	720	8.25 (209.6)	6.58 (166.9)	5.50 (139.7)	40 (18)
	1000	8.25 (209.6)	6.58 (166.9)	5.50 (139.7)	40 (18)
	1500	8.25 (209.6)	6.58 (166.9)	5.50 (139.7)	40 (18)
	1925	8.25 (209.6)	6.58 (166.9)	5.50 (139.7)	40 (18)
	2000	8.25 (209.6)	6.58 (166.9)	5.50 (139.7)	40 (18)
	2160	8.25 (209.6)	6.58 (166.9)	5.50 (139.7)	40 (18)
	2250	8.25 (209.6)	6.58 (166.9)	5.50 (139.7)	40 (18)

The pressure rating is the maximum working pressure at temperatures -20° F to 100° F. Contact Stream-Flo Industries Ltd. for working pressures beyond this temperature range. Weight and dimensional information for reference only and subject to change without notice. Weights and dimensions can be confirmed at time of order.

FIG10-FIG71-VERSION-01-B16.11