

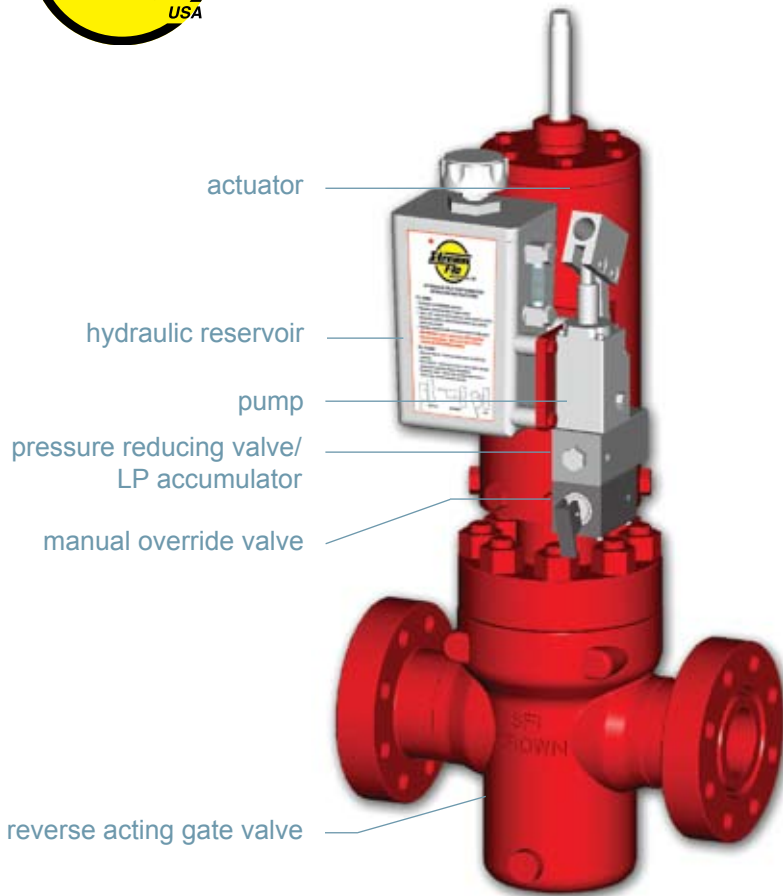

ESD TECHNOLOGY

Crown Hydraulic Self-Contained Emergency Shutdown System



Stream-Flo's Crown Hydraulic Self-Contained, Spring-Fail Closed Emergency Shutdown (ESD) System is used for the automatic closing of gate valves on wellheads and flow lines under emergency conditions.

The system consists of a hydraulic actuator, a manual hydraulic pump and control assembly, and a reverse-acting gate valve.

The system can be tripped by several means. The most common mean is a pressure pilot which trips the system when it senses pressure fluctuations outside of the specified control range.

DESIGN FEATURES

Actuator

The actuator is spring-return, hydraulically opened for use on reverse-acting gate valves. The valve is opened and closed by the application and release of hydraulic pressure.

Modular design allows the actuator to be changed independently of the gate valve and bonnet assembly, providing ease of service or replacement.

Fail-safe operation is ensured with the optimized valve stem diameter. Upon loss of hydraulic pressure, the combined forces of the actuator spring and the line pressure acting on this optimally-sized valve stem will, in every circumstance, close the emergency shutdown system when required.

Excellent serviceability of the hydraulic seals. Seals can be accessed from the top of the

actuator even with the actuator mounted on the valve, providing ease of maintenance and minimum downtime.

Safely contained spring is precompressed and assembled in the spring canister. The spring cannot be released inadvertently, providing a safe operating and service environment.

External position indicator is connected directly to the valve stem and protrudes from the top of the actuator. It provides visual indication of valve position as well as mounting for accessories such as limit switches and lock-open devices.

Sealed spring canister protects all internal components including the spring from hostile environments such as moisture, salt, dust and sand.

DESIGN FEATURES

Bonnet Assembly

Built-in gate stops both upper and lower are incorporated in the bonnet. This enables the valve and bonnet to be completely assembled and stroke set independent of the actuator.

Metal-to-metal stem back seat provides a means of sealing to isolate the stem packing cavity in the event of a stem

packing failure in addition to providing an upper travel stop for the gate.

Self-energized stem packing can operate in a wide range of temperatures from -50°F/-46°C to +350°F/+177°C.* The Teflon seal material is suitable for extreme operating environments.

Pump Control Unit

This unit consists of a manual pump, a pressure-reducing valve with a built-in accumulator, and a manual override valve. This unit is designed for ease of removal and modular component replacement.

Rugged check valve in the pump assembly provides leak-tight checking of the high pressure hydraulic fluid back flow, ensuring reliable performance and low maintenance services.

Large suction filter in the pump provides high flow and extended trouble-free service life.

Large capacity low pressure accumulator accommodates changes in control fluid volume due to thermal expansion. The large capacity allows for flexibility in pilot and pump placement.

Low pressure relief valve ensures reliable supply of low pressure, protecting tripping devices from damage and malfunction caused by excessive control pressure.

Responsive trip valve provides rapid system tripping and valve closure. It also serves as the manual valve closing mechanism.

Fire Protection is incorporated into the pump control unit by means of a fusible plug which in the event of fire will trip the system to close the valve.

Minimum valve closing time is ensured due to the optimally-sized hydraulic fluid flow path.

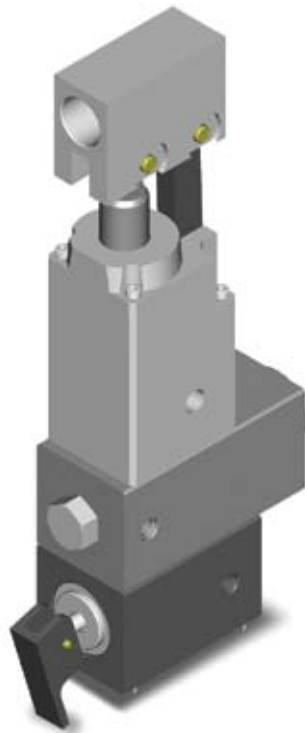

Typical Hydraulic Schematic

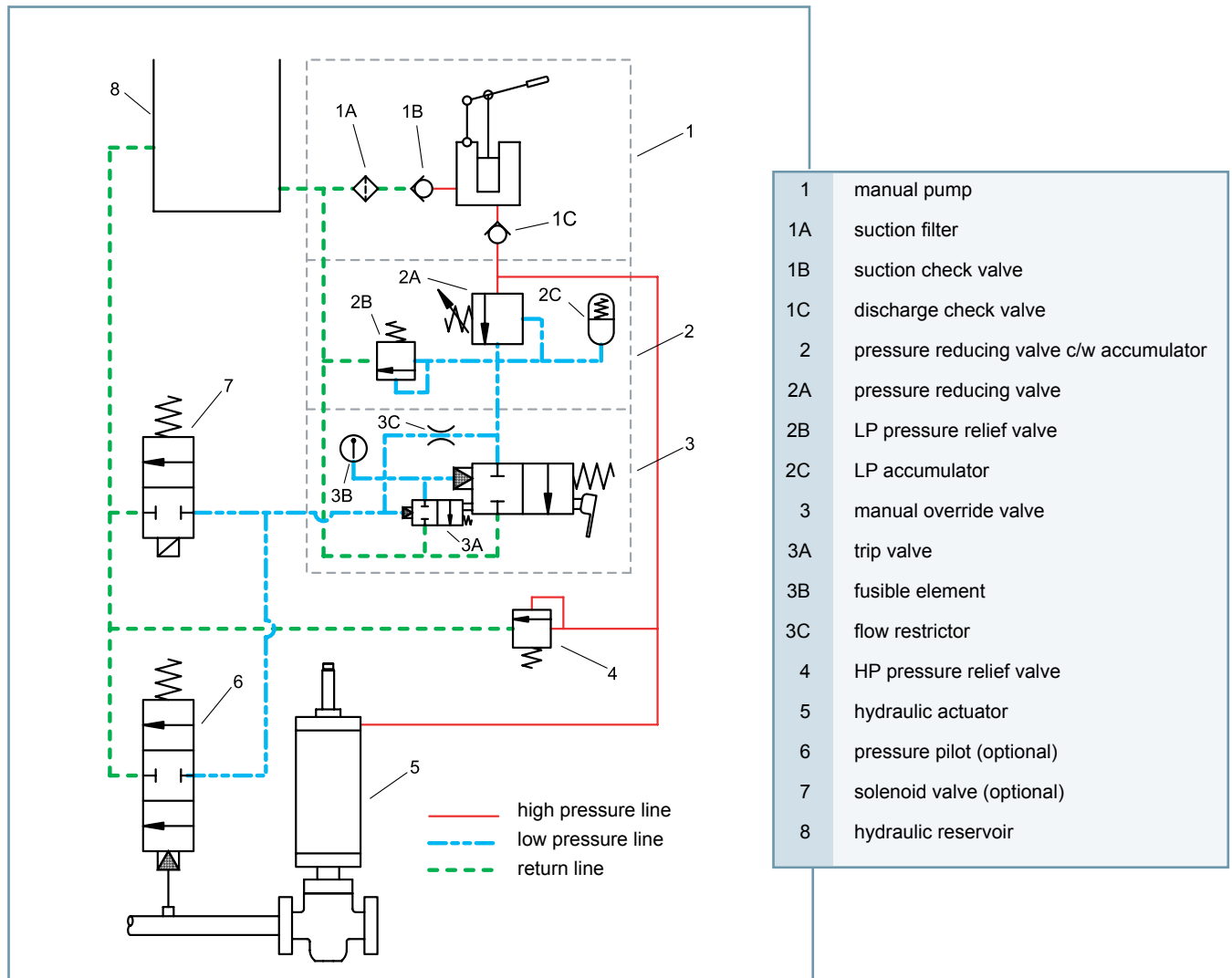

General Specifications*

Actuator	maximum operating pressure temperature range operating media	3500 psi -50°F/-46°C to +180°F/+82°C clean hydraulic fluid
Bonnet Assembly	maximum operating pressure service condition temperature range	up to 15,000 psi API Material Class AA thru HH API Temperature Class L thru X (-50°F/-46°C to +350°F/+177°C)
Pump Control Unit	temperature range seals component materials	-50°F/-46°C to +180°F/+82°C Teflon, polyurethane and nitrile anodized aluminum and stainless steel

*General specifications only. Please contact Stream-Flo Industries for other requirements.



CANADIAN EXPERTISE



GLOBAL STRENGTH

Stream-Flo USA Inc.
Wellhead Sales & Engineering
25227 Grogan's Mill Road
Suite 125
The Woodlands, TX 77380
Tel 281.296.1641
Fax 281.296.1611

Canadian Sales
400 Bow Valley Square One
202 - 6 Avenue SW
Calgary Alberta Canada
T2P 2R9
Tel 403.269.5531
Fax 403.266.3307

**Head Office and
Manufacturing Facility**
4505 - 74 Avenue
Edmonton Alberta Canada
T6B 2H5
Tel 780.468.6789
Fax 780.469.7724

International Sales
Indonesia
62.21.7918.1234
United Arab Emirates
971.2.676.0130
Algeria
213.29.738.910
United Kingdom
353.87.798.3582