

Double Box Bushing

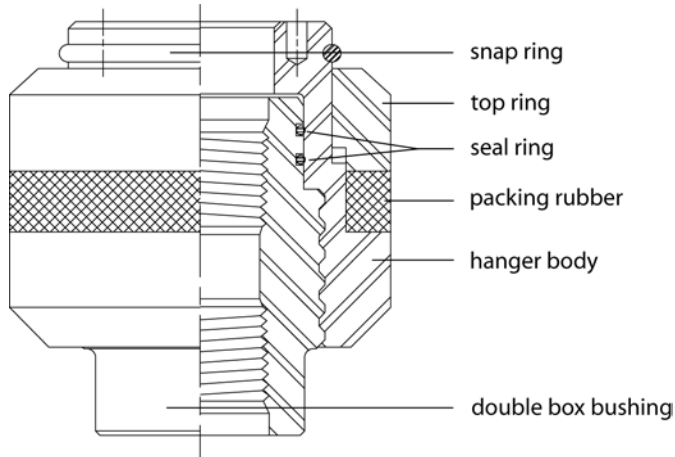

The Crown double box bushing tubing hanger is a mandrel-type hanger which consists of two separate pieces, an inner mandrel bushing and an outer housing. The bushing has a box tubing connection on the top and bottom, and an external left-hand acme thread on the outside. The housing which fits into the tubing head has an internal acme thread which matches the bushing.

A hanger housing can be manufactured to fit in virtually any Crown tubing head. This allows for economical conversion of existing equipment. This hanger provides an easy and safe method of applying and removing tension in a tubing string. It is effective when used with any packer or anchor which requires the tubing to be set in tension. The double box bushing hanger also provides an annular seal in the tubing head.

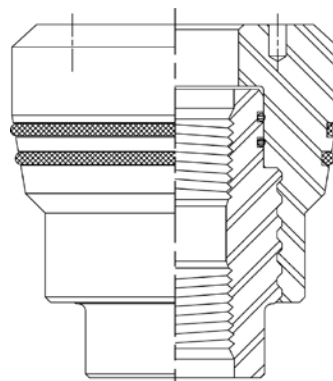

A

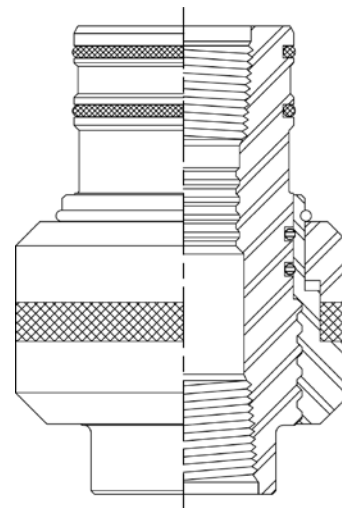

CTC1A-EN

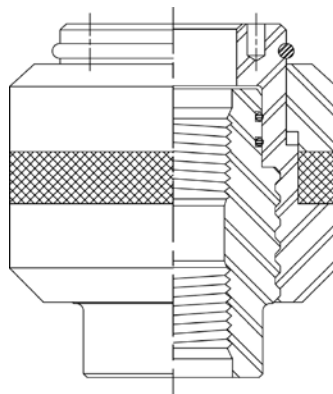

CTC-1B

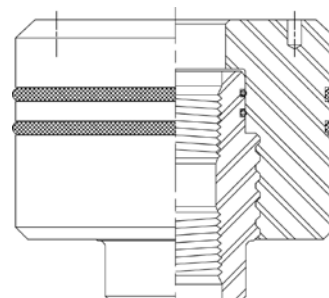

CU