



## Clapper, Bonnet & Seat Design Features

### Conduit Clapper

A conduit clapper is used to assure the passage of pigs, spheres and inspection equipment.

This is accomplished in incorporating an elliptical face clapper, which forms the shape of the pipeline, thus reducing void spaces which may cause a pig, sphere, or inspection instrument to hang up and become lodged in the valve body.

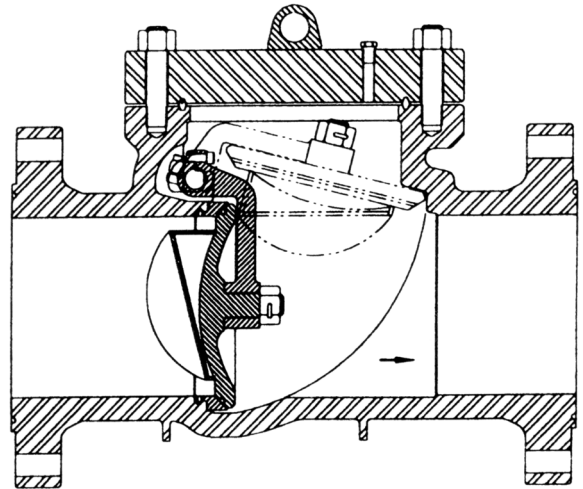

### Bonnet Gasket Material and Coatings

All Crown subsea check valves are manufactured with a RTJ bonnet gasket.

Bonnet gasket options include:

- soft iron cadmium plated (standard)
- soft iron zinc plated
- soft iron epoxy coated
- 316 stainless steel or other customer specified materials

### 45° Seat Face Designs

An angled seat face (45°) aids in the passage of pigs, spheres and inspection equipment during reverse flow through the check valve. Angling the seat face eliminates the flat face associated with a conventional swing check valve.

