

CB-15-A, CB-11-AO

The CB-15-A bottom hole test adapter is an ideal choice where an integral flanged unit is preferred. These adapters are furnished in various sizes and working pressures up to 5,000 psi. The CB-11-AO is the preferred unit for 10,000 psi and higher pressure applications.

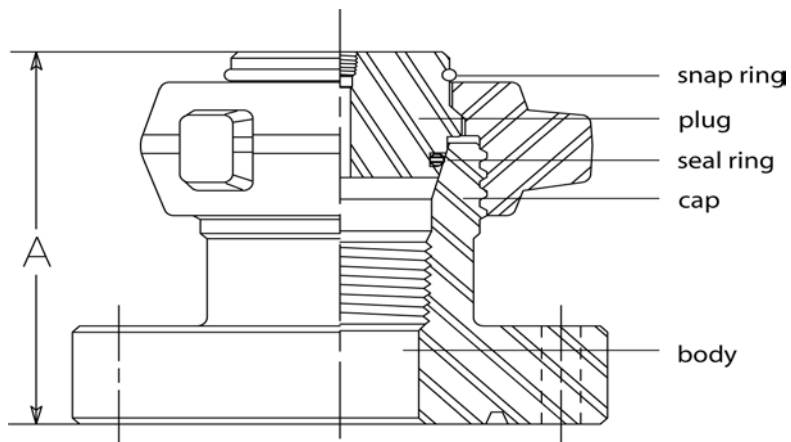

CB-15-A

Table of Dimensions

Size	A
2 1/16 - 2000	7.15
2 1/16 - 5000	7.78
2 9/16 - 2000	7.53
2 9/16 - 5000	8.03
3 1/8 - 2000	8.16
3 1/8 - 3000	8.41
3 1/8 - 5000	8.79

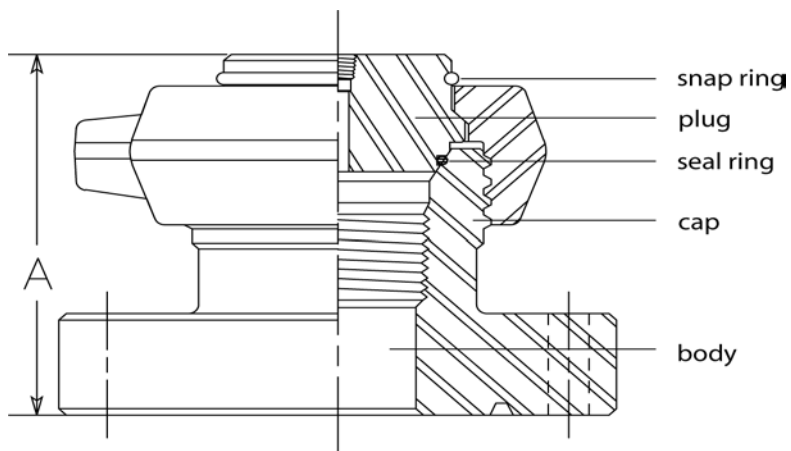

CB-11-AO

Table of Dimensions

Size	A
2 1/16 - 10,000	8.64
2 9/16 - 10,000	8.64
3 1/16 - 10,000	10.69
4 1/16 - 10,000	11.44